

EIVD18-87036B 3.6mm Lens, Black Casing

EIVD18-87036 3.6mm Lens, White Casing

EIVD18-87060B 6.0mm Lens, Black Casing

EIVD18-87060 6.0mm Lens, White Casing

700TVL Weather Proof IR Dome Camera



USER MANUAL

FEATURES

- 1/3" Sony Super HAD CCD II
- Sony Effio-E DSP
- 700 TV Lines
- 3.6mm or 6.0mm Lens
- 18 IR LED; IR distance 50ft / 15m
- Various Angle LED Combination - Uniform IR light distribution for optimum viewing angle
- 2DNR
- Photodiode Design for accurate IR LED trigger activation
- Double Glass: Effectively reducing the internal reflection
- Aluminum design for better heat dissipation
- 12V DC
- IP66 Rating



Please read the Manual before attempting to use this product.

Specifications and appearance are subject to change without notice.



CAUTION

**RISK OF ELECTRIC SHOCK
DO NOT OPEN!**



**TO REDUCE THE RISK OF ELECTRICAL SHOCK,
DO NOT OPEN COVERS (OR BACK).
NO USER SERVICEABLE PARTS INSIDE.
REFER SERVICING TO QUALIFIED
SERVICE PERSONNEL.**



Disposal of Old Electrical & Electronic Equipment (Applicable in the European Union and other European countries with separate collection systems).

This symbol on the product or on its packaging indicates that this product shall not be treated as household waste. Instead it shall be handed over to the applicable collection point for the recycling of electrical and electronic equipment. By ensuring this product is disposed of correctly, you will help prevent potential negative consequences for the environment and human health, which could otherwise be caused by inappropriate waste handling of this product. The recycling of materials will help to conserve natural resources. For more detailed information about recycling of this product, please contact your local city office, your household waste disposal service or the shop where you purchased the product.

CAUTION

1. Never point the camera toward the sun

Do not expose the lens directly to the sun or to strong light as this may damage the pick-up device.

2. Handle this camera with care

Avoid any shock or bumping of the camera. Improper handling could damage the camera.

3. Requires a proper operating environment

This camera is designed for indoor use. The allowable temperature range for operation of this camera is between 14°F ~ 122°F / -10°C ~ 50°C.

4. Clean the front face or lens

It is recommended that the surface be cleaned every 3~6 months. Cleaning should be done by using a chamois, a very fine soft cloth, lens tissue, or cotton tipped applicator and ethanol to carefully remove any fingerprint or dust.

5. Check the power source voltage

The power source voltage should be within the specified range. (Camera must meet the specifications). Camera must be connected to a surge protector at all times.

6. Objects and liquid entry

Never push objects of any kind into this camera as this may touch dangerous voltage points of short out parts that could result in a fire or electric shock. Never spill any kind of liquid on the video product.

7. Servicing

Do not attempt to service this video product by yourself as opening or removing covers may expose you to dangerous voltage or other hazards. Refer all service to qualified servicing personnel.

8. Damage requiring service

Unplug this video product from the wall outlet and refer service to qualified servicing personnel under the following conditions:

- a. When the power supply cord or plug is damaged.
- b. If liquid has been spilled, or objects have fallen into the video product.
- c. If the video product has been exposed to rain or water.
- d. If the video product has been dropped or the cabinet has been damaged.
- e. When the video product exhibits a distinct change in performance.

LIMITED WARRANTY

This product is covered under warranty for one (1) year from the date of purchase. The warranty will automatically be voided if any of the following occurs:

1. Camera sticker is removed

If the camera sticker is removed, we will not be able to confirm any information regarding when and where the product was purchased. We have no other way to verify the purchase record without the serial number on the camera sticker; therefore, it should not be removed.

2. Camera is modified in any way

If the camera is scratched, damaged, or modified in a manner not described in this manual, the warranty will be voided immediately. It is the customer's responsibility to keep the camera in good condition.

3. Video or power cable is cut

The video cable and the power cable should not be tampered with. Cutting or modifying of the cables will result in termination of the warranty.

PACKAGE CONTENTS

- A. One (1) Vandal Proof IR Dome Camera with power/video cable
- B. Four (4) Mounting Screws
- C. Four (4) Wall Anchors
- D. One (1) User Manual

A.



B.



C.



D.



* For any returns, please include all components listed above with original packaging in **Resalable Condition**. **Absolutely No Returns** will be accepted if any component is missing/damaged.

DIMENSIONS

Unit: mm

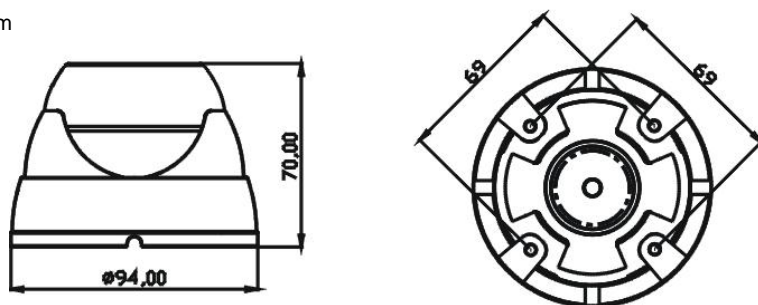

SPECIFICATION

Model (NTSC)	EIVD18-87036B	EIVD18-87036	EIVD18-87060B	EIVD18-87060
Model (PAL)	EIVD18-87036BP	EIVD18-87036P	EIVD18-87060BP	EIVD18-87060P
Casing Color	Black	White	Black	White
Sensor	1/3" Sony Super HAD CCD II			
DSP	Sony Effio-E			
Total Pixels	NTSC: 1028(H) x 508(V) / PAL: 1028(H) x 596(V)			
Effective Pixels	NTSC: 976(H) x 494(V) / PAL: 976(H) x 582(V)			
Resolution	700 TV lines			
Synchronizing System	Internal			
Scanning System	2:1 Interlace			
S/N Ratio	More than 48 dB(AGC OFF)			
Electronic Shutter	Auto/1/60 (1/50) ~1/100,000 sec.			
Min. Illumination	0.1 Lux / F2.0 (50IRE)			
Video Output	1.0 Vp-p / 75 ohm composite			
IR LED	18pcs IR			
IR Distance	50ft / 15m			
IR Trigger	7 Lux \pm 3 Lux IR ON / OFF			
Auto White Balance	1800°K~10500°K			
Lens Type	3.6mm Lens		6.0mm Lens	
Power Source	12V DC \pm 10% / 1A			
Power Consumption	2.88W			
Current	240mA (Max)			
IP Rating	IP66 weather proof			
Operating Temperature	14°F ~ 122°F / -10°C ~ 50°			
Storage Temperature	-4°F ~ 158°F / -20°C ~ 70°C			
Dimension	2.75(H) x 3.70(Dia) inches / 70(H) x 94(Dia) mm			
Weight	0.66 lbs / 0.32 kg			

*Specifications are subject to change without notice

MADE IN TAIWAN

Copyright © 2012. All Rights Reserved.
www.sentrvus.com